



ES



EN



## EXTRACTOR DE TORNILLOS ROTOS 5010CD BROKEN SCREW EXTRACTOR 5010CD

### Características / Characteristics

Juego de 5 extractores de tornillos rotos. / Set of 5 broken screws pullers.

Compuesto por 5 machos, 5 tuercas, 5 brocas y 10 guías para exterior. / Contains 5 males, 5 nuts, 5 bits and 10 external guides

Las brocas deben girar a derechas. / The bits should turn clockwise.

En maleta de plástico de color rojo. / Red plastic box.



### Instrucciones / Instructions

Para trabajar correctamente es muy importante / For a proper puller work, is important:

1- Utilizar el extractor más grande posible. / Use the biggest possible extractor.

2- Trabajar con la tuerca a unos 10mm de distancia. / Work with the nut 10 mm away.

A menos distancia suele romper el espárrago, a más distancia se retuerce muy fácilmente. / If the distance is too short, the screw used to break. If the distance is too long, the screw easily twists.

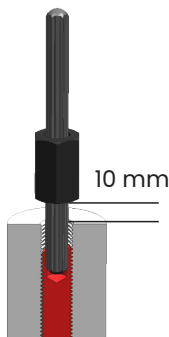

| Screws       | M5 | M6 | M8 | M10 | M12 | M14 | M16 |
|--------------|----|----|----|-----|-----|-----|-----|
| Par max. Nm. | 8  | 11 | 27 | 55  | 90  | 130 | 205 |

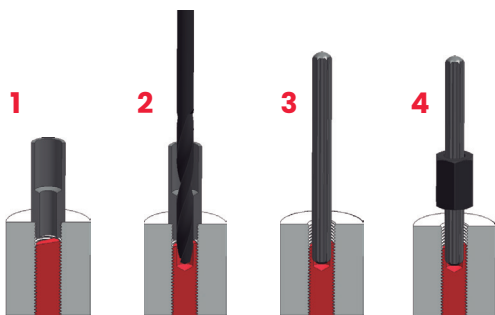

## INTERIOR INTERNAL

Cuando el tornillo se rompe quedando una parte dentro se utilizan las guías de interior. / *When the screw is broken leaving a part inside, the interior guides are used.*

## EXTERIOR EXTERNAL

Cuando el tornillo se rompe quedando una parte fuera se utilizan las guías de exterior. / *When the screw is broken leaving a part outside the outer guides are used.*

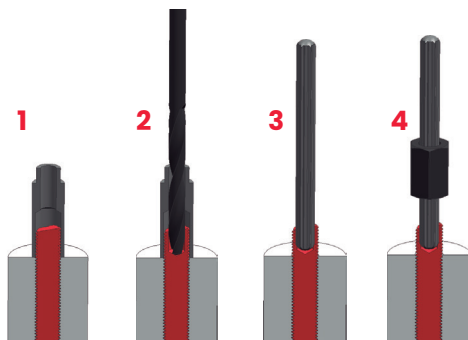

**Elegir el extractor y broca más grande posible. / Select the biggest possible extractor**

1. Coloque la guía sobre el tornillo. / *Place the guide sleeves over the stud.*
2. Taladre el tornillo. / *Drill the stud (left).*
3. Clave el extractor con un martillo. / *Drive the extractor into the hole with a hammer.*
4. Coloque la tuerca estriada en el extractor, evite que la tuerca toque la cara de la pieza. / *Place the grooved nut over the extractor, avoid touching the stud.*
5. Gire la tuerca con una llave para sacar el tornillo / *Twist nut to the left.*



Utilice todos los equipos de protección individual (EPIs) necesarios. / *Use all necessary safety equipments.*

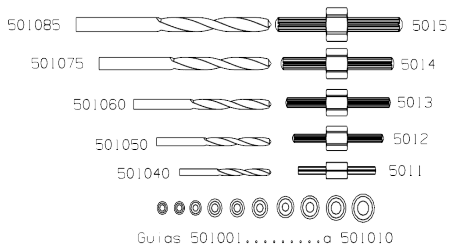
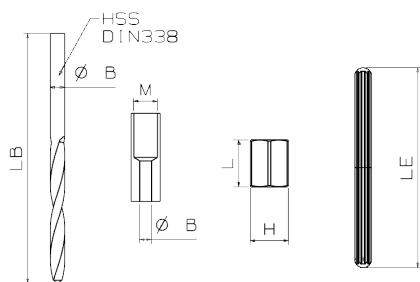

| Broca / Drills    | 501040 | 501050 | 501060 | 501075 | 501085 |
|-------------------|--------|--------|--------|--------|--------|
| ØB                | 4      | 5      | 6      | 7,5    | 8,5    |
| Long. / Length LB | 74     | 85     | 92     | 108    | 115    |

Las brocas son a derechas. / Drills are right hand

| Guías / Guides | 501001 | 501002 | 501003 | 501004 | 501005 | 501006 | 501007 | 501008 | 501009 | 501010 |
|----------------|--------|--------|--------|--------|--------|--------|--------|--------|--------|--------|
| Ø exterior M   | M5     | M6     | Ø7     | M8     | M8     | Ø9     | M10    | Ø11    | M12    | M14    |
| Ø exterior N   | /      | M6     | M8     | 3/8"   | 1/2"   | M10    | 7/16"  | M12    | M14    | M16    |
| Broca / Drills | 501040 | 501040 | 501040 | 501040 | 501050 | 501050 | 501060 | 501060 | 501075 | 501085 |
| Macho / Male   | 501101 | 501101 | 501101 | 501101 | 501201 | 501201 | 501301 | 501301 | 501401 | 501501 |

| Tuercas / Nuts | 501102 | 501202 | 501302 | 501402 | 501502 |
|----------------|--------|--------|--------|--------|--------|
| Largo / Long L | 16     | 16     | 16     | 16     | 6      |
| Hexágono H     | 10     | 13     | 14     | 16     | 18     |

| Machos / Males    | 501101 | 501201 | 501301 | 501401 | 501501 |
|-------------------|--------|--------|--------|--------|--------|
| Long. / Length LE | 57     | 68     | 78     | 84     | 94     |
| Par Máx. Nm.      | 18     | 30     | 60     | 120    | 180    |